

# CARBURETTERS

## THE AUXILIARY STARTING CARBURETTER

### Description (Fig. 11)

The enrichment apparatus for starting is, in effect, an auxiliary carburetting system. The main body casting (1) containing a solenoid-operated valve and fuel metering system is illustrated as a separate unit attached by means of a ducted mounting arm to the base of the carburetter fuel inlet.

The auxiliary carburetter forms, therefore, a separate unit additional to the normal float chamber retained by the hollow cross-drilled bolt.

Fuel is supplied to the base of the jet (9), which is obstructed to a greater or lesser degree by the tapered slidable needle (10).

When the device is in action air is drawn from atmosphere through the air intake (7) and thence through the passage (8), being carburetted with fuel as it passes the jet (9). The mixture is thence carried upwards past the shank of the needle (10) through the passage (14) and so past the aperture provided between the valve (3) and its seating (2). From here it passes directly to the inlet manifold through an external feed pipe.

The device is brought into action by energizing the winding of the solenoid (5) from the terminals (6). The centrally located iron core (4) is thus raised magnetically, carrying with it the ball-jointed disc valve (3) against the load of the small conical spring and thus uncovering the aperture provided by the seating (2).

Considering the function of the slidable needle (10), it will be seen that this is loaded upwards in its open position by means of the light compression spring (11) which abuts against a disc (12) attached to the shank of the needle. The needle continues upwards through the vertically adjustable stop (13) in which it is slidable mounted and it finally terminates in an enlarged head.

Depression within the space surrounding the spring (11) is directly derived from that prevailing in the induction tract, and this exerts a downward force upon the disc (12), which is

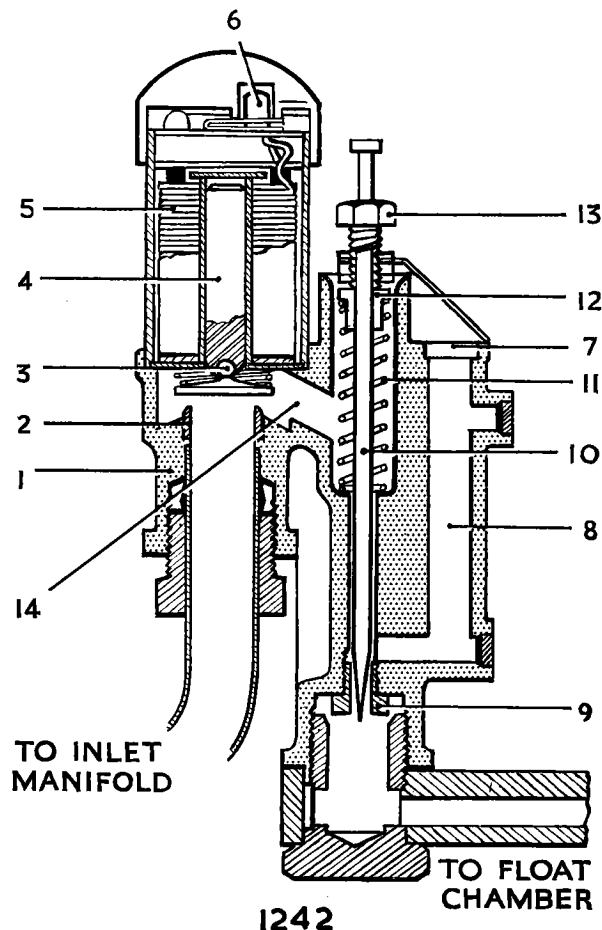

Fig. 11. Sectioned view of the auxiliary starting carburetter.

provided with an adequate clearance with its surrounding bore. This tends to overcome the load of the spring (11) and to move the needle downwards, thus increasing the obstruction afforded by the tapered section which enters the jet (9).

The purpose of this device is to provide two widely different degrees of enrichment, the one corresponding to idling or light cruising conditions and the other to conditions of open throttle or full-power operation. In effect, under the former conditions the high induction depression prevailing will cause the disc (12) to be drawn downwards, drawing the tapered needle into the jet (9), while under the latter, the lower depression existing in the induction tract will permit the collar to maintain its upward position with the needle withdrawn from the jet.

The tuning elements concerned in this device are the size and degree of taper of the lower end of the needle (10), the diameter of the disc (12), the load provided by the spring (11) and the degree of movement permitted to the needle assembly, as determined by the adjustment of the stop (13).

The solenoid (5) is energized by means of a thermostatically operated switch housed in the inlet manifold water jacket. This is arranged to bring the apparatus into action at temperatures below about 30—35°C. (86—95°F).

#### **Adjustment**

The engine must be at its normal running temperature and the carburetters correctly adjusted before any attempt is made to tune the auxiliary enrichment device.

As it can generally be assumed that the tapered form of the needle (10), the strength of the spring (11), and the diameter of the disc (12) have already been appropriately chosen, tuning is generally confined to the adjustment of the stop screw (13). It will be appreciated that the main purpose of this adjustment is to limit the downward movement of the needle, the head of which abuts against the upper surface of the stop screw at the lower extremity of its travel. The final downward movement of this needle determines, as has been described, the degree of enrichment provided under idling conditions

with the auxiliary carburetter in operation. An appropriate guide to its correct adjustment in this respect is provided by energizing the solenoid when the engine has already attained its normal temperature. The stop screw (13) should then be so adjusted that the mixture is distinctly although not excessively rich, that is to say, until the exhaust gases are seen to be discernibly black in colour, but just short of the point where the engine commences to run with noticeable irregularity.

Anti-clockwise rotation of the stop screw will, of course, raise the needle under these conditions and increase the mixture strength, while rotation in the opposite direction will have the opposite effect. In order to energize the solenoid under conditions when the thermostatic switch will normally have broken the circuit, it is merely necessary to short-circuit the terminal of the thermostatic switch directly to earth with a screwdriver and flick open the throttles when the starting device will be heard to come into operation with a pronounced hissing noise.